

Operational Guidelines

MS02 Microwave Sensor

1 Safety Guide

Related components must have a separation of electrical safety devices with low voltage protection operating conditions. All installation and maintenance work must be carried out by the professionals.

2 Name of the components

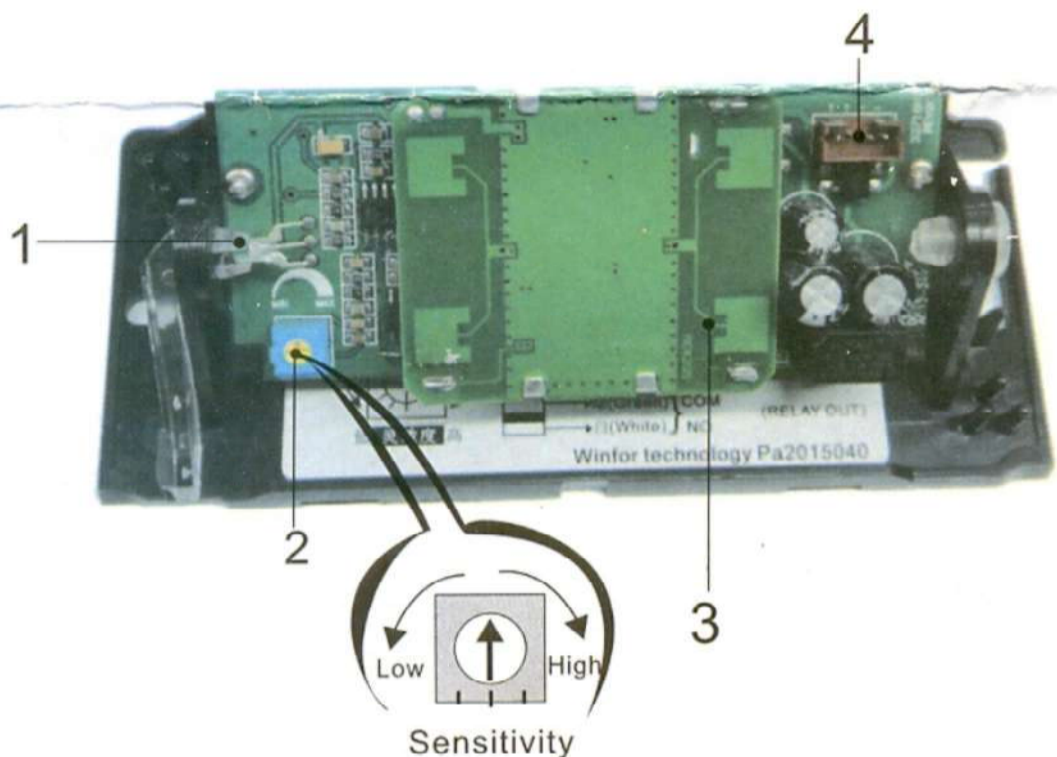

- 1. Luminous diode
- 2. Sensibility adjust screw
- 3. MDU sensor module
- 4. Wire plug

3 Open the shell

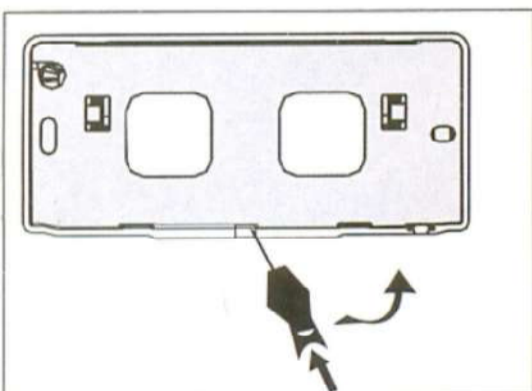

Not being installed

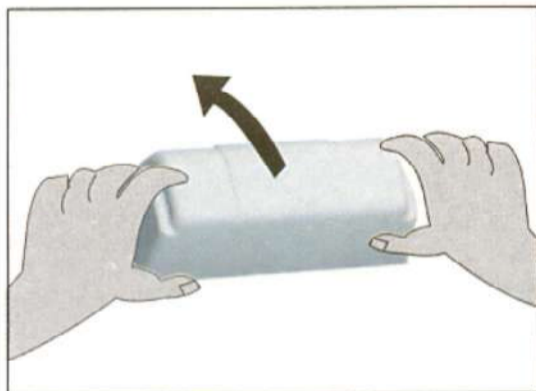

Being installed on the wall

4 Drilling

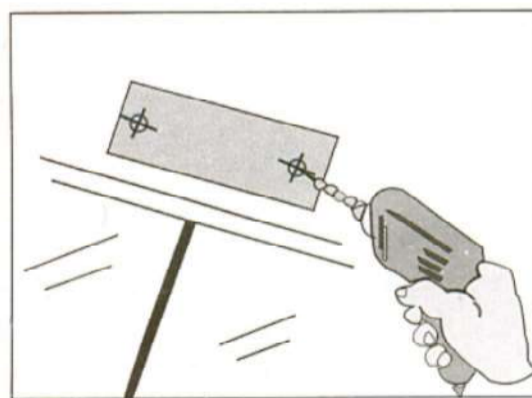

Installing on wall, use the attached template to drill holes.

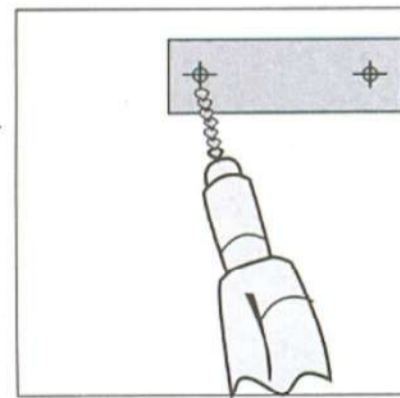

Installing on ceiling, use the attached template to drill holes.

5 Fixing

The screws are pre-placed on the bracket

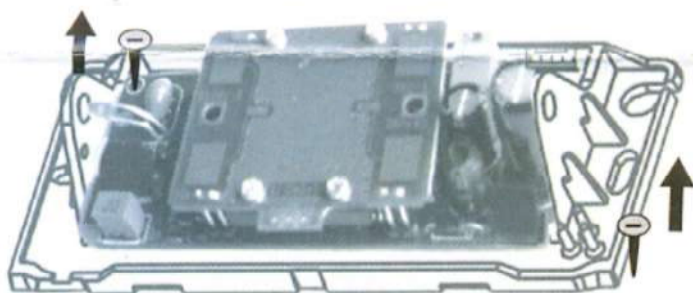

Remove the screws, fixed the main sensor body on the wall.

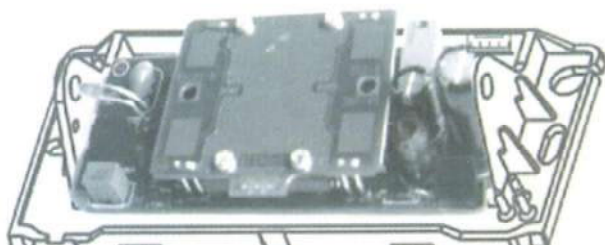

6 Wiring diagram

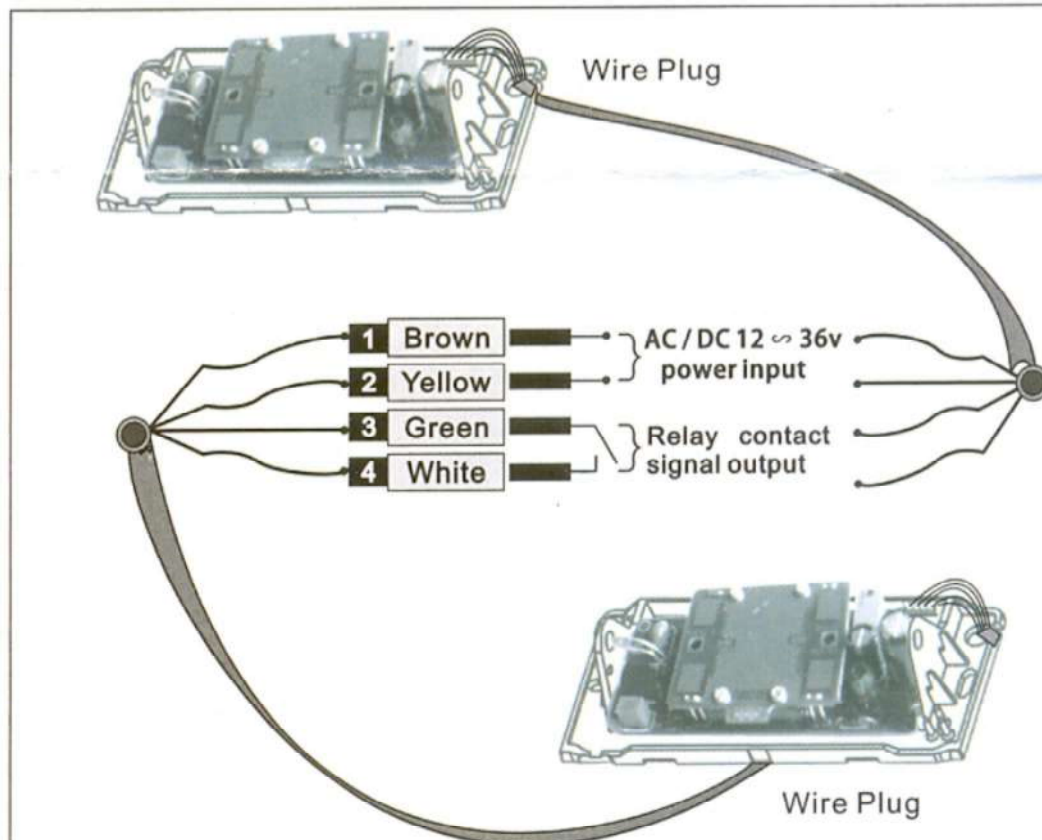

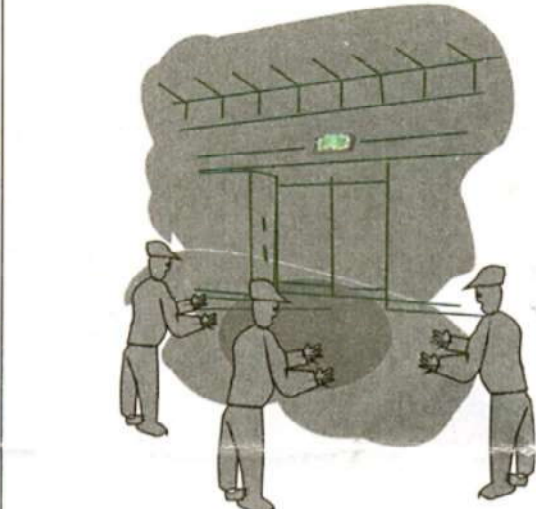

When the power be offered, microwave sensor starts to detect the environment around.

Stand at different position to detect the detection area.

Keep the microwave sensor beyond the detection area for 5s.

Sensibility adjuster screw to adjust the detection area.

- The smallest range 1.5 × 1.0m
- The largest range 4 × 2.5m

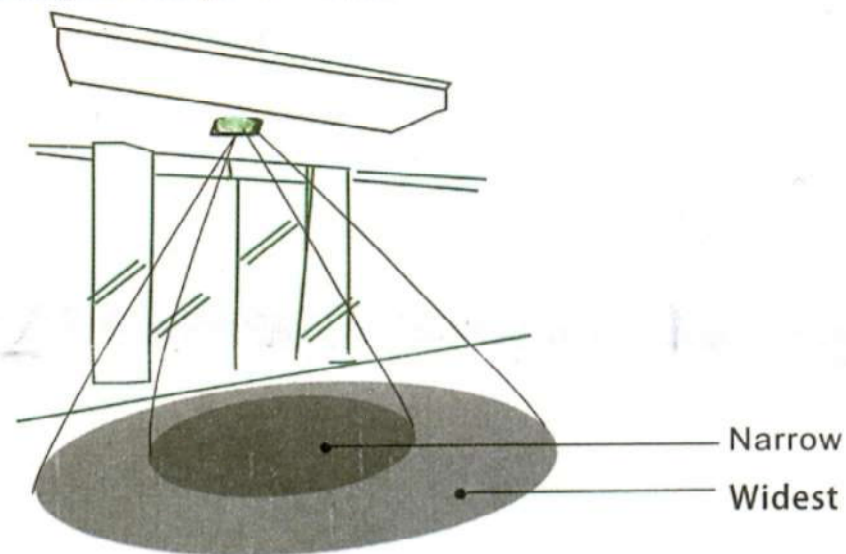

The maximum installation height is 4m.
Note: The lower the temperature is, the wider detection area is.

9 Adjust the detection position

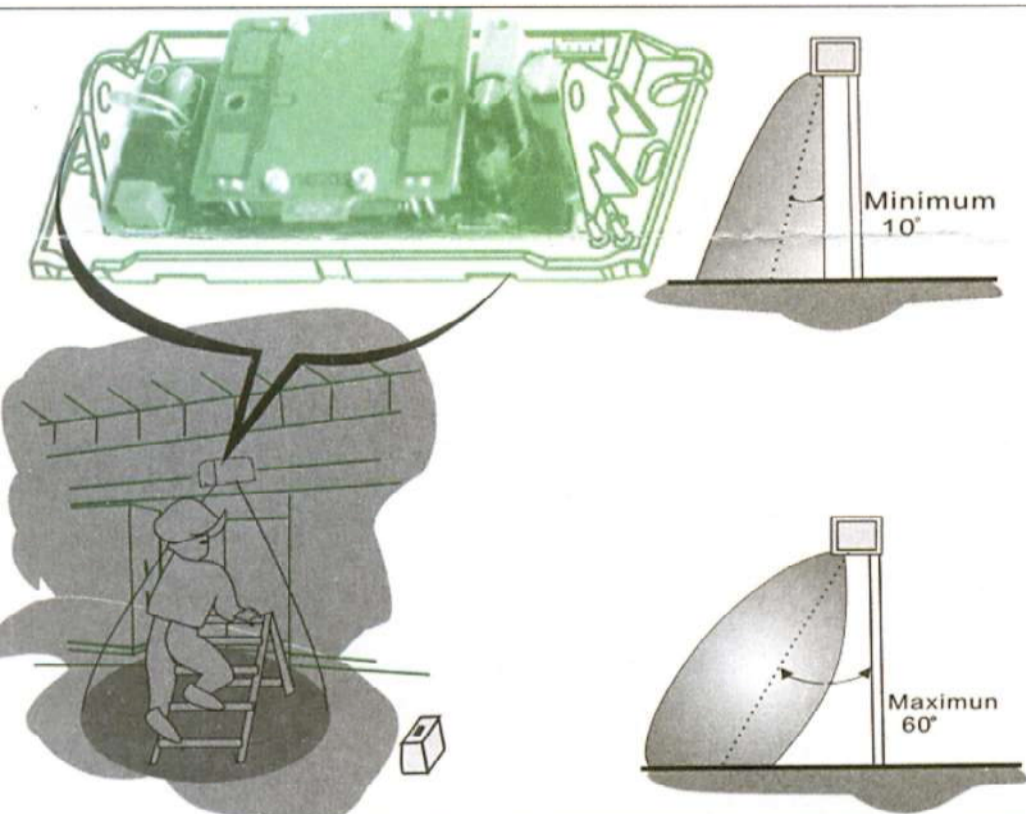

Rotate the bracket of microwave sensor to form an angle(10-60 degree) between the MDU sensor module and installation wall in order to adjust the detection area.

10 Covering

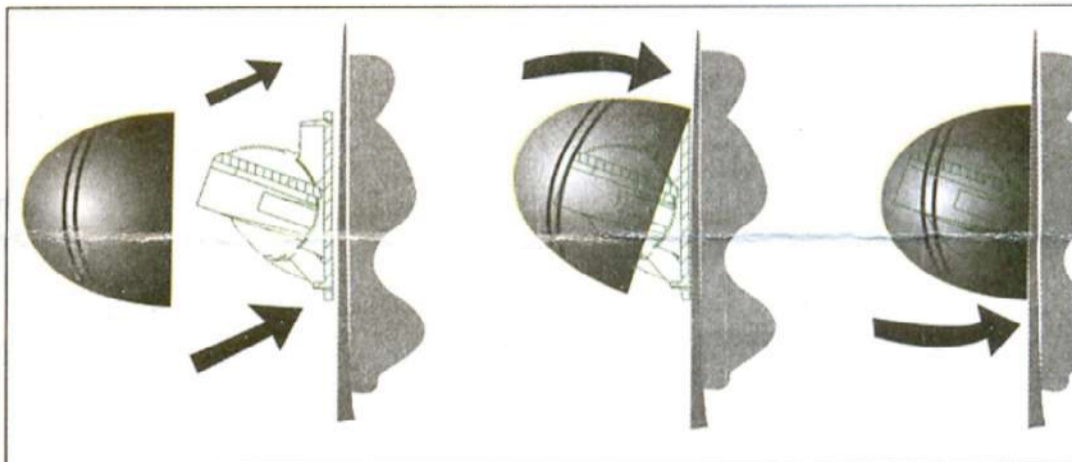

11 The possibility of interference

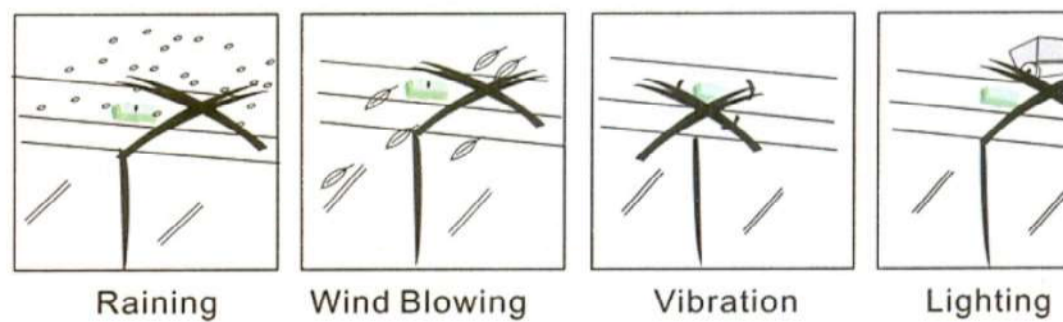

12 The technical details (Order Code: C9T5603)

Power Supply	AC/DC 12~36V
Current consumption	Static Current 45mA Action Current 105mA
Environmental temperature	-20°C +60°C
Environmental humidity	0-90%, without condensation
Wave form	X-Band 10.525 GHZ
Output	<=20dBm
Relay output	N.O.-point output (Relay)
Maximum voltage	48V AC/DC
Maximum current	0.5A AC/1.0A DC
Minimum switching power	1mA
The largest power switch	55VA/24W
Weight	220g
Protection level	1P 54
Size	131L×61W×46H (mm)



MANUFACTURER'S STATEMENT

Read this operation manual carefully before use to ensure proper operation of the sensor. Failure to read this operation manual may cause improper sensor operation and may result in serious injury or death of person. The meanings of the symbols are as follows. Please study the following first and then read the contents of this operation manual.

WARNING	Disregard of warning may cause the improper operation causing death or serious injury of person.
CAUTION	Disregard of caution may cause the improper operation causing injury of person or damage to objects.
NOTE	Special attention is required to the section of this symbol.

NOTE

- This sensor is a non-contact switch intended for header mount / wall mount of an automatic door. Do not use for any other applications. This sensor cannot be used for industrial doors or shutters, when used, proper operation and safety cannot be guaranteed.
- When setting the sensor's detection area, make sure there is no traffic around the installation site.
- Before turning the power on, check the wiring to prevent damage or malfunction of equipments that are connected to the sensor.
- Only use the sensor as specified in the operation manual provided.
- Be sure to install the sensor in accordance with the local laws and standards of the country in which the sensor is installed.
- Before leaving the job site make sure that the sensor is operating properly and instruct the building owner/operator on proper operation of the door and the sensor.
- The sensor setting can only be changed by an installer or service engineer. When changed, register the changed setting and dates in the maintenance logbook accompanying the door.

WARNING	Do not wash, disassemble, rebuild or repair the sensor, otherwise it may cause electric shock or breakdown of equipments.
Danger of electric shock.	

SPECIFICATIONS

Model	: OA-AXIS I / OA-AXIS II	Output	: OA-AXIS I / Form C relay
Cover color	: Silver / Black		: 50V 0.3A Max. (Resistance load)
Mounting height	: 2.0 (6'7") to 3.5m (11'5")		: OA-AXIS II /
Detection area	: See DETECTION AREA		: 1st to 3rd rows / Form C relay
Detection method	: Active Infrared Reflection		: 50V 0.3A Max. (Resistance load)
Depth angle adjustment	: 1st to 3rd rows / -6° to +6°		: 3rd to 5th rows / Form C relay
	: 4th and 5th rows / +26° to +44°		: 50V 0.3A Max. (Resistance load)
Power supply	: 12 to 24VAC(±10%)	Output hold time	: Approx. 0.5 sec.
	: 12 to 30VDC(±10%)	Response time	: <0.3 sec.
Power consumption	: OA-AXIS I < 3VA	Operating temperature	: -20 to +55°C (-4 to 131°F)
	: OA-AXIS II < 4VA	IP rate	: IP44
Operation LED	: Green / Stand-by	Weight	: 320g (11.2oz)
	: Blinking Red / 1st row detection	Accessories	: 1 Cable 3m (9'10")
	: Red / 2nd row detection		: 1 Operation manual
	: Orange / 3rd to 5th rows detection		: 2 Mounting screws
			: 1 Mounting template
			: 1 Area adjustment tool

NOTE The specifications herein are subject to change without prior notice due to improvements.

OUTER DIMENSIONS AND PART NAMES

DETECTION AREA

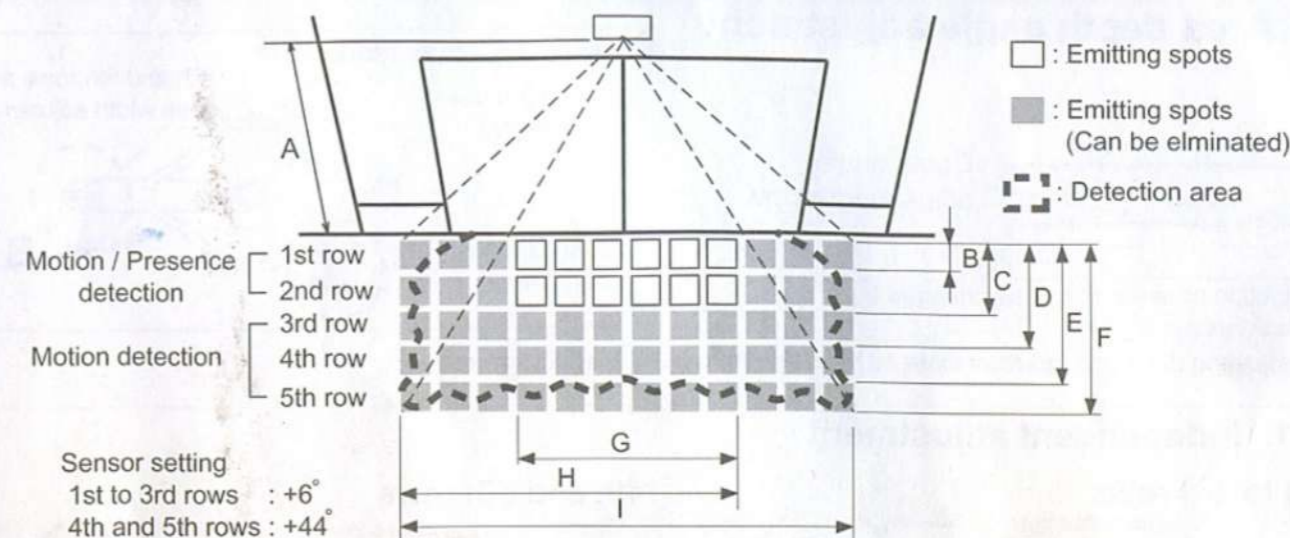

	[m(feet,inch)]				
A	2.20(7'2 5/8")	2.50(8'2 7/16")	2.70(8'10 5/16")	3.00(9'10 1/8")	3.50(11'5 13/16")
B	0.14(5 1/2")	0.16(6 5/16")	0.18(7 1/16")	0.20(7 7/8")	0.23(9 1/16")
C	0.42(1'4 9/16")	0.48(1'6 7/8")	0.52(1'8 1/8")	0.58(1'10 13/16")	0.67(2'2 3/8")
D	0.82(2'8 5/16")	0.93(3' 5/8")	1.00(3'3 3/8")	1.10(3'7 5/16")	1.30(4'3 3/16")
E	1.35(4'5 1/8")	1.54(5' 5/8")	1.66(5'5 3/8")	1.85(6' 13/16")	2.16(7'1 1/16")
F	1.90(6'2 13/16")	2.17(7'1 1/16")	2.34(7'8 1/8")	2.60(8'6 3/8")	3.03(9'11 5/16")
G	1.33(4'4 3/8")	1.51(4'11 7/16")	1.63(5'4 3/16")	1.81(5'11 1/4")	2.11(6'11 1/16")
H	2.05(6'8 11/16")	2.32(7'7 5/16")	2.51(8'2 13/16")	2.79(9'1 13/16")	3.26(10'8 3/8")
I	2.78(9'1 7/16")	3.15(10'4")	3.40(11'1 7/8")	3.79(12'5 3/16")	4.42(14'6")

NOTE The actual detection area may become smaller depending on the ambient light, the color / material of the object or the floor as well as the entry speed of the object.

*The values of the chart above is of the emitting spots, but not of the detection area.

INSTALLATION

- NOTE** The following conditions are not suitable for the sensor installation.
- Fog or exhaust emission around the door.
 - Wet floor
 - Vibrating header or mounting surface.
 - Moving objects or a heating radiator in the detection area.
 - Highly reflecting floor or the presence of highly reflecting objects around the door.

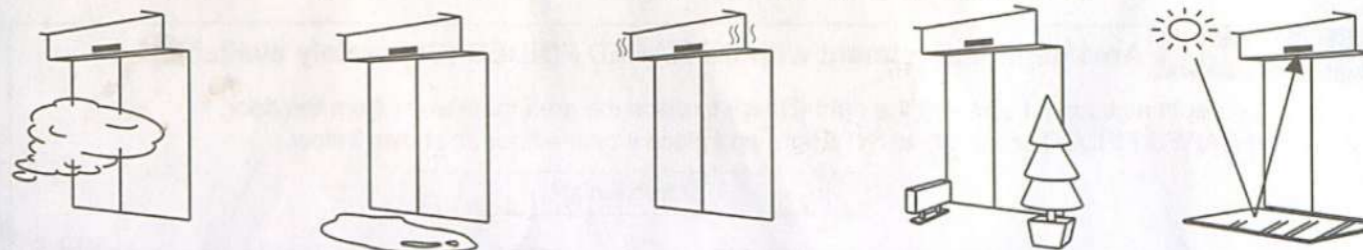

- Affix the mounting template at the desired mounting position.
- Drill two mounting holes of $\phi 3.4\text{mm}$ ($\phi 1/8"$).
- To pass the cable through to the header, drill a wiring hole of $\phi 8\text{mm}$ ($\phi 5/16"$).
- Remove the mounting template.
- Remove the housing cover. Attach the sensor to the mounting surface with two mounting screws.

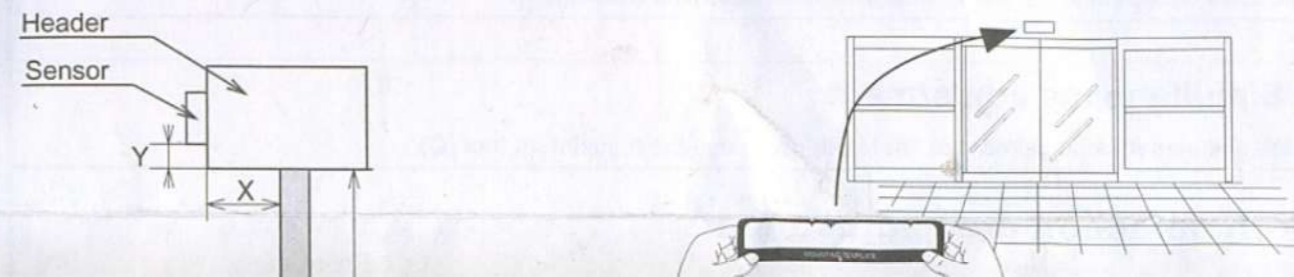

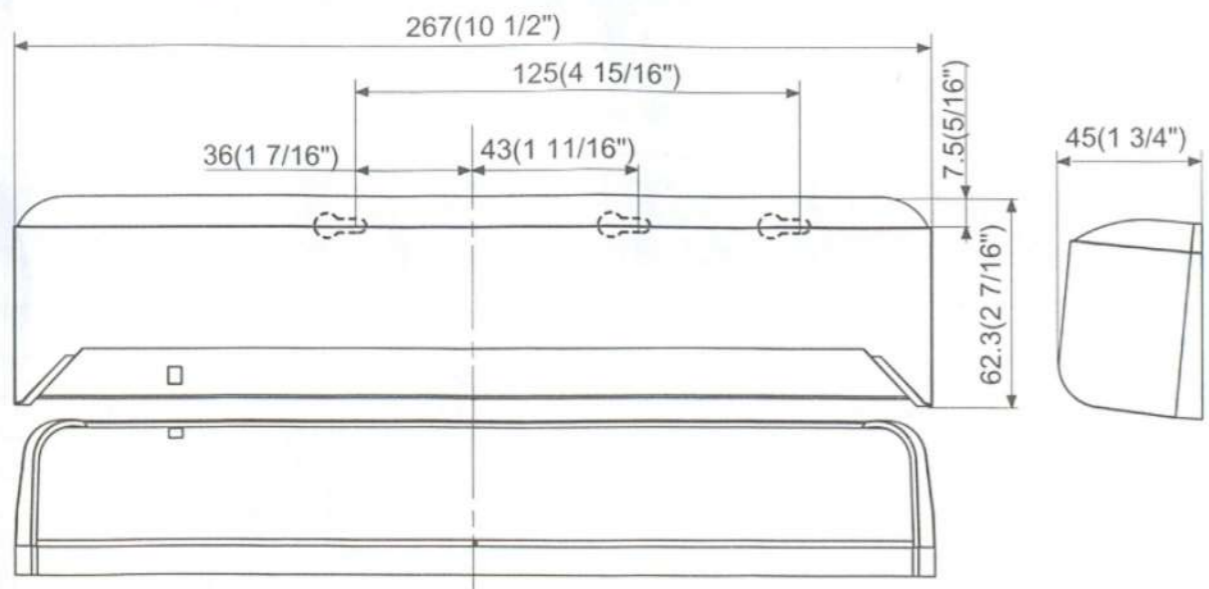

[mm (inch)]

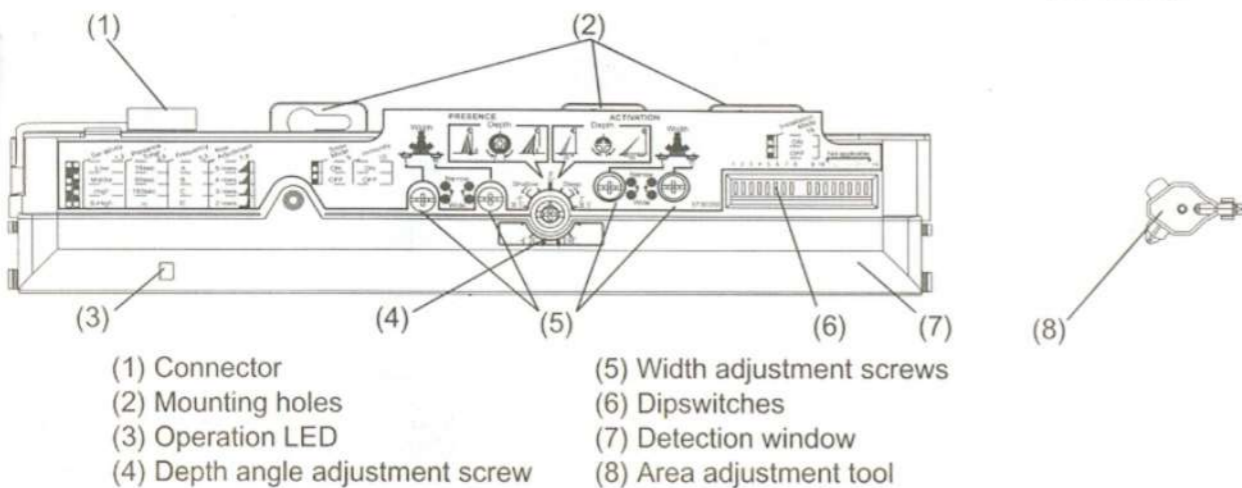

- (1) Connector
- (2) Mounting holes
- (3) Operation LED
- (4) Depth angle adjustment screw
- (5) Width adjustment screws
- (6) Dipswitches
- (7) Detection window
- (8) Area adjustment tool

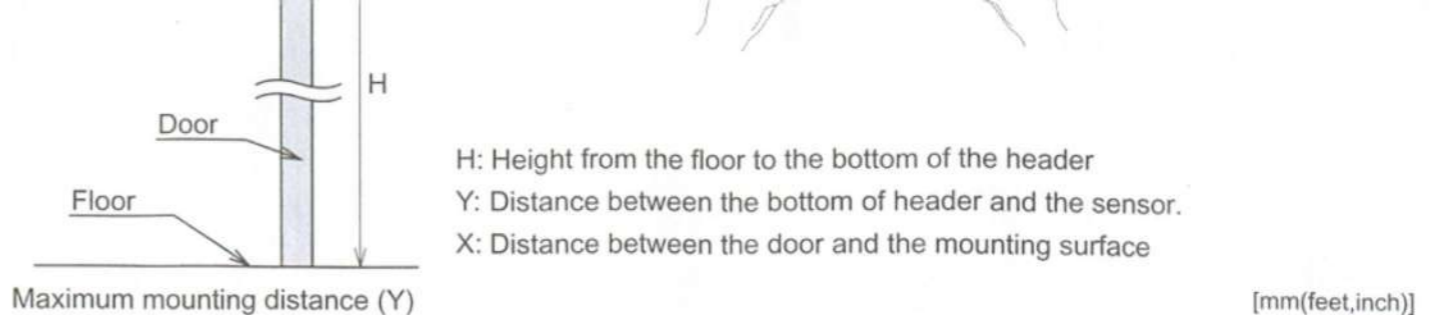

H: Height from the floor to the bottom of the header
 Y: Distance between the bottom of header and the sensor.
 X: Distance between the door and the mounting surface

Maximum mounting distance (Y) [mm(feet,inch)]

X \ H	2,000 (6' 6")	2,200 (7' 2")	2,500 (8' 2")	3,000 (9' 10")
0	No limit			
50 (1 15/16")	200 (7 7/8")	200 (7 7/8")	200 (7 7/8")	200 (7 7/8")
100 (3 15/16")	200 (7 7/8")	200 (7 7/8")	200 (7 7/8")	200 (7 7/8")
150 (5 7/8")	130 (5 1/8")	150 (5 7/8")	170 (6 11/16")	200 (7 7/8")
200 (7 7/8")	-	110 (4 5/16")	130 (5 1/8")	150 (5 7/8")
250 (9 13/16")	-	-	-	120 (4 3/4")
300 (11 13/16")	-	-	-	-

CAUTION
 Risk of getting caught.
 Make sure to affix the mounting template as described in the above chart. Otherwise, it can be dangerous since there may be no presence detection area around the threshold. Install the sensor as low as possible on the header.

NOTE The sensor mounting position may be limited depending on the header thickness and the mounting height.

Wire the cable to the door controller properly as shown in the drawing below.

OA-AXIS I

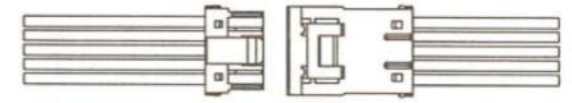

- Grey } Power supply
- Grey } 12 to 24VAC ±10%
- Grey } 12 to 30VDC ±10%
- White } Common (COM.)
- Yellow } Normally open (N.O.)
- Green } Normally closed (N.C.)

OA-AXIS II



- Grey } Power supply
 - Grey } 12 to 24VAC ±10%
 - Grey } 12 to 30VDC ±10%
 - White } Common (COM.)
 - Yellow } Normally open (N.O.)
 - Green } Normally closed (N.C.)
 - White Str. } Common (COM.)
 - Yellow Str. } Normally open (N.O.)
 - Green Str. } Normally closed (N.C.)
- 3rd to 5th* rows output
 1st to 3rd* rows output

*The outputs from the 3rd row overlaps.

WARNING
 Danger of electric shock.
 Before starting the procedure, ensure that the power is turned OFF. When passing through the cable to the hole, make sure not to tear the shield, otherwise it may cause electric shock or breakdown of the sensor.

1. Plug the connector of the sensor.
2. Supply power to the sensor. Adjust the detection area and set the dipswitches. (See ADJUSTMENTS)

NOTE Make sure to connect the cable correctly to the door controller before turning the power ON. To enable the presence detection, do not enter the detection area for 10 seconds after supplying the power.

Place the housing cover.
 If wiring is to be exposed, break the knockout.

WARNING
 Danger of electric shock.
 Do not use the sensor without the cover. When using the cable knockout, install the sensor indoors or use the rain-cover (Separately available) otherwise electric shock or breakdown of the sensor may occur.

Area depth angle adjustment

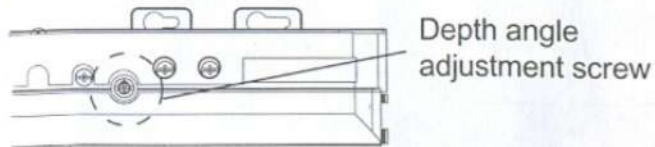

The detection area depth can be changed by the area adjustment tool.

When adjusting the 1st to 3rd rows close to the door, follow 3-7 Installation mode.

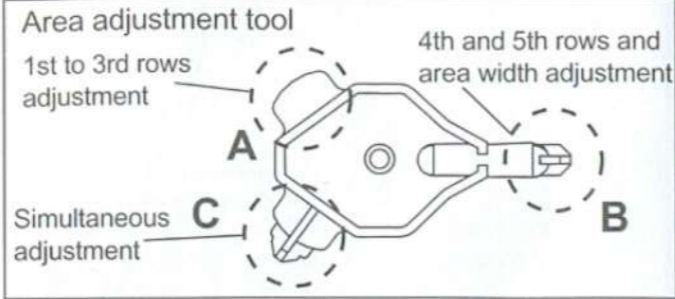

1-1. Independent adjustment

1st to 3rd rows

Depth angle adjustment screw for 1st to 3rd rows



Use the area adjustment tool (A) as shown above and change the depth of the detection area by turning the depth angle adjustment screw.

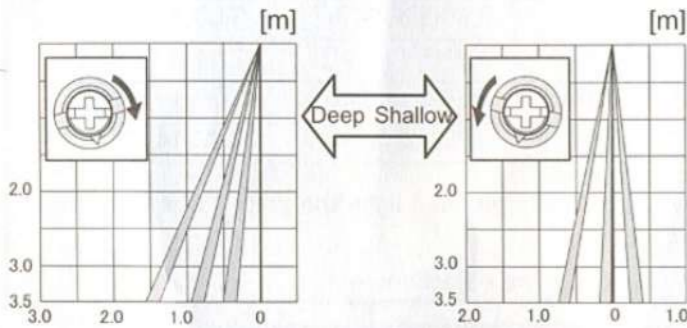

4th and 5th rows

Depth angle adjustment screw for 4th and 5th rows



Use the area adjustment tool (B) as shown above and change the depth of the detection area by turning the depth angle adjustment screw.

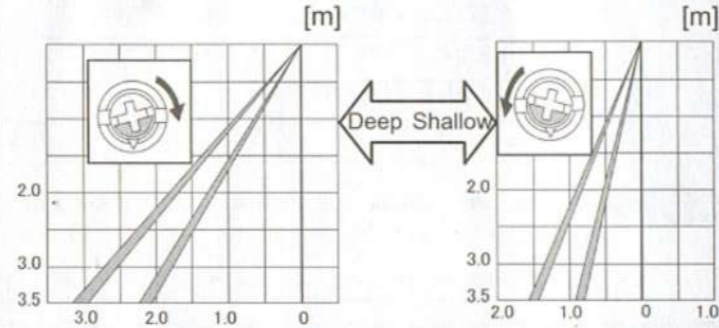

Check the area position with Red LED of the Operation LED using a tool such as a reflecting mirror.

NOTE Make sure the detection area does not overlap with the door / header, otherwise ghosting / signal saturation may occur.
Do not place any highly reflecting objects in the detection area, otherwise signal saturation may occur.

REFERENCE Area depth adjustment with INFRARED FINDER (Separately available)

1. Turn the depth adjustment screw to the right (Deep) to place the area most away from the door.
2. Set INFRARED FINDER sensitivity to "H" (High) and place it on the floor as shown below.

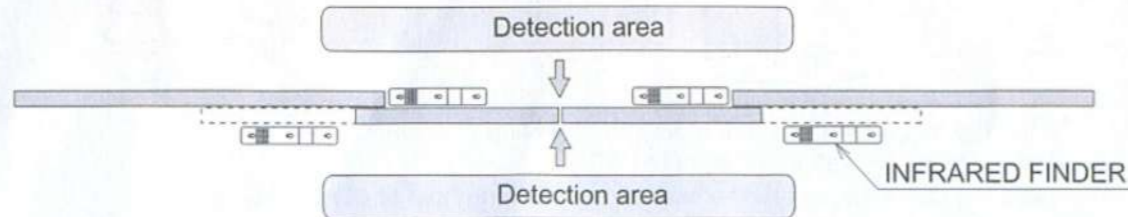

3. Turn the depth adjustment screw to the left (Shallow) until the emitting area is placed at the position where INFRARED FINDER is in the low detection status (Slow Red blinking).

1-2. Simultaneous adjustment

For the simultaneous adjustment of 1st to 5th rows, use the adjustment tool (C).

2 Width detection area adjustment

3-4 Setting the area depth

The 5th, 4th, and 3rd rows can be eliminated by combining dipswitches 7 and 8.

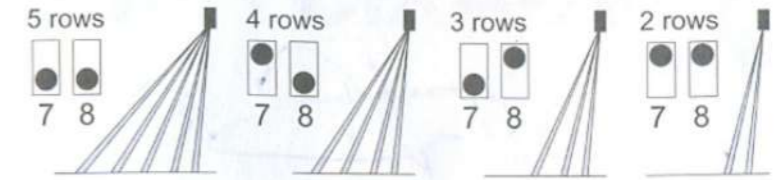

*When 2 rows setting is selected, only the presence detection area remains.

NOTE Always check the area according to the expected entry speed and determine the appropriate number of rows.
When setting motion and motion / presence detection area separately, make sure that there is no gap between two areas.

3-5 Setting the snow mode

Set this switch to ON, if the sensor is used in a region with snow.

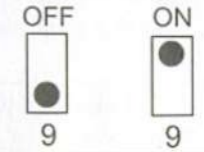

3-6 Setting the immunity

Set this switch to ON, when less influence by the header vibration is required.

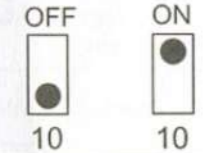

3-7 Installation mode

Use this switch to ON when adjusting the presence detection area close to the door face.

- * During the installation mode, only the 1st row remain.
- * Door open state
- * Operation LED glows yellow.

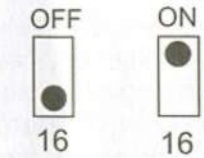

CHECKING

Check the operation according to the chart below.

- ① White : COM. ④ White Str. : COM.
- ② Yellow : N.O. ⑤ Yellow Str. : N.O.
- ③ Green : N.C. ⑥ Green Str. : N.C.

Entry	Power off	Outside of detection area	Entry into 4th or 5th row	Entry into 3rd row	Entry into 2nd row	Entry into 1st row
Status	-	Stand-by	Motion detection active	Motion/Presence detection active	Presence detection	
Operation LED	None	Green	Orange		Red	Blinking Red
OA-AXIS I	Output	① ② ③	① ② ③	① ② ③		
OA-AXIS II	Output from 1st to 3rd rows*	④ ⑤ ⑥	④ ⑤ ⑥	④ ⑤ ⑥		
	Output from 3rd to 5th rows*	① ② ③	① ② ③	① ② ③	① ② ③	

*The outputs from the 3rd row overlaps.

INFORM BUILDING OWNER / OPERATOR OF THE FOLLOWING ITEMS

⚠ WARNING

1. Always keep the detection window clean. If dirty, wipe the window lightly with a damp cloth. (Do not use any cleaner or solvent.)
2. Do not wash the sensor with water.
3. Do not disassemble, rebuild or repair the sensor yourself, otherwise electric shock may occur.
4. When an operation LED blinks green, contact your installer or service engineer.
5. Always contact your installer or service engineer when changing the settings.

2 Width detection area adjustment

1st to 3rd rows

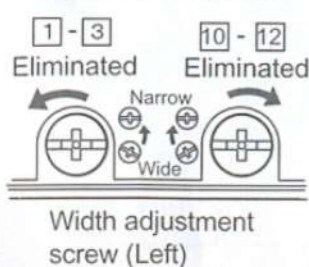

4th and 5th rows

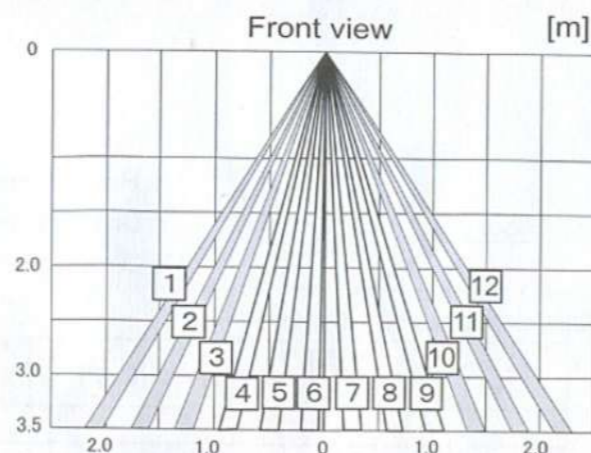
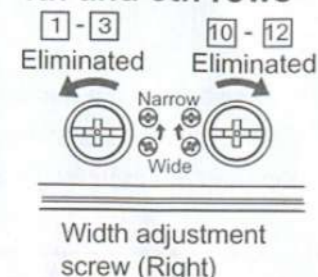

NOTE

The actual detection area may become smaller depending on the ambient light, the color / material of the object and the floor as well as the entry speed of the object.

3 Dipswitch settings

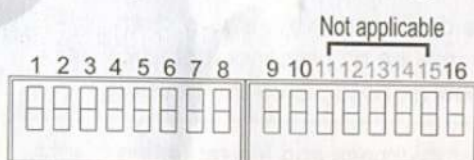

- 1,2 : Sensitivity
- 3,4 : Presence detection timer
- 5,6 : Frequency
- 7,8 : Row adjustment
- 9 : Snow mode
- 10 : Immunity
- 11 to 15 : Not applicable
- 16 : Installation mode

3-1 Setting the sensitivity

Normally set to "Middle". "Low" decreases the sensitivity and "High / S-High" increases the sensitivity.

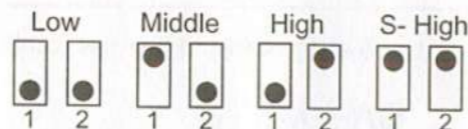

3-2 Setting the presence detection timer

The 1st and 2nd rows have the presence detection function. The presence detection timer can be selected from 4 settings.

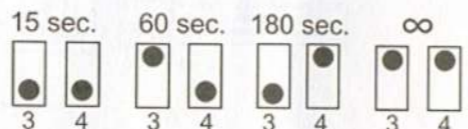

NOTE To enable the presence detection, do not enter the detection area for 10 seconds after setting the timer.

3-3 Setting the frequency

When using more than two sensors close to each other, set the different frequency for each sensor by combining dipswitch 5 and 6.

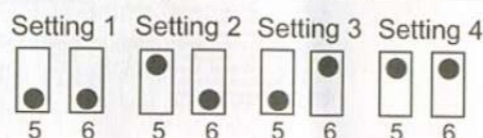

3. Do not disassemble, rebuild or repair the sensor yourself, otherwise electric shock may occur.
4. When an operation LED blinks green, contact your installer or service engineer.
5. Always contact your installer or service engineer when changing the settings.
6. Do not paint the detection window.

NOTE

1. When turning the power on, always walk-test the detection area to ensure proper operation.
2. Do not place any objects that move or emit light in the detection area. (e.g. Plant, illumination, etc.)

TROUBLESHOOTING

Problem	Operation LED	Possible cause	Possible countermeasures
Door does not open when a person enters the detection area.	None	Power supply voltage. Wrong wiring or connection failure.	Set to the stated voltage. Check the wires and connector.
	Unstable	Wrong detection area positioning.	Check ADJUSTMENTS 1 & 2 .
		Sensitivity is too low.	Set the sensitivity higher.
		Short presence detection timer.	Set the presence detection timer longer.
Door opens when no one is in the detection area. (Ghosting)	Unstable	Dirty detection window.	Wipe the detection window with a damp cloth. (Do not use any cleaner or solvent.)
		Vibration of the header.	Set the sensitivity lower or the immunity to ON.
		Water drops on the detection window.	Use the rain-cover (Separately available). Or install in a place keeping the waterdrops off.
		The detection area overlaps with that of another sensor.	Check ADJUSTMENTS 3-3 .
		The detection area overlaps with the door / header.	Adjust the detection area to "Deep" (Outside).
		Reflecting objects in the detection area. Or reflecting light on the floor.	Remove the objects.
		Sensitivity is too high.	Set the sensitivity lower.
		It snows and pours.	Set the snow mode to ON.
		Objects that move or emit light in the detection area. (Ex.Plant, illumination,etc.)	Remove the objects.
		Wet floor.	Check the installation condition referring to INSTALLATION on the reverse side.
Door remains open	Red or Orange	Sudden change in the detection area.	Check ADJUSTMENTS 3-1 & 3-2 . If the problem still persists, hard-reset the sensor.(Turn the power OFF and ON again.)
	Proper	Wrong wiring or connection failure.	Check the wires and connector.
	Twice Green blinking	The relay is reaching the end of its life cycle.	Contact your installer or the sales engineer.
	Slow Green blinking	Signal saturation	Remove highly reflecting objects from the detection area. Or lower the sensitivity. Or change the area angle.
The detection area overlaps with the door / header.		Adjust the detection area to "Deep" (Outside).	
Door remains closed	Proper	Wrong wiring or connection failure.	Check the wires and connector.

OPTEX CO.,LTD.

5-8-12 Ogoto Otsu 520-0101, Japan
TEL.:+81 (0)77-579-8700
FAX.:+81 (0)77-579-7030
WEBSITE: www.optex.co.jp

OPTEX Technologies Inc.

3882 Del Amo Blvd., Suite 604
Torrance, CA 90503 U.S.A.
TEL.: +1 (310) 214-8644
FAX.: +1 (310) 214-8655
TOLL-FREE: 800-877-6656
WEBSITE: www.optextechnologies.com

OPTEX Technologies B.V.

Tiber 2, 2491 DH The Hague,
The Netherlands
TEL.: +31 (0)70-419-41-00
FAX.: +31 (0)70-317-73-21
E-MAIL: info@optex.nl
WEBSITE: www.optex.nl